

Pin	Signal Name	Mating Sequence	Pin	Signal Name	Mating Sequence
A1	GND	First	B12	GND	First
A2	SSTXp1	Second	B11	SSRXp1	Second
A3	SSTXn1	Second	B10	SSRXn1	Second
A4	Vbus	First	B9	Vbus	First
A5	CC1	Second	B8	SBU2	Second
A6	Dp1	Second	B7	Dn2	Second
A7	Dn1	Second	B6	Dp2	Second
A8	SBU1	Second	B5	CC2	Second
A9	Vbus	First	B4	Vbus	First
A10	SSRXn2	Second	B3	SSTXn2	Second
A11	SSRXp2	Second	B2	SSTXp2	Second
A12	GND	First	B1	GND	First
SHELL	GND		SHELL	GND	

NOTE:

- MATERIALS:
 - INSULATOR: HIGH TEMPERATURE PLASTIC UL 94 V-0,
 - CONTACT: COPPER ALLOY($t=0.15mm$)
 - SHELL: STAINLESS STEEL($t=0.20mm$)
- ELECTRICAL CHARACTERISTICS:
 - CONTACT RESISTANCE: $40m\Omega$ Max FOR INITIAL, $10m\Omega$ CHANGE AFTER TEST MEASURE AT $20mV$, $100mA$.
 - CONTACT CURRENT RATING: $5A$ FOR VBUS PIN, $1.25A$ FOR VCONN PIN.
 - DIELECTRIC WITHSTANDING VOLTAGE: $100V$ AC R.M.S.
 - INSULATION RESISTANCE $100M\Omega$ Min
 - OPERATING TEMPERATURE: $-40^{\circ}C \sim 85^{\circ}C$
- MECHANICAL CHARACTERISTICS:
 - MATING FORCE: $5 \sim 20$ N.
 - UNMATED FORCE: $8 \sim 20$ N AFTER TEST
 - DURABILITY: $10,000$ CYCLES
- PLATING:
 - TERMINAL CONTACT: (SEE TAB) GOLD PLATING ALL OVER 50μ Min NICKEL AND 80μ Min Tin ALL OVER 50μ Min NICKEL ON SOLDER AREA
 - OUT SHELL: 50μ Min. NICKEL ALL OVER
 - INNER SHELL: DEGREASE
- PART NUMBER: 1186-32XXX-23A

ZDX 深圳市兆达鑫科技有限公司
Shenzhen Zhao Xin Technology Co., Ltd.

TOLERANCE: X.XX ±0.30 X.XXX ±0.20 X.XXX ±0.10 X.X ±0.10 X.X ±0.05 X.X ±0.02	DRAWN BY : 刘志强	DATE : 2015.08.18	PART NAME: TYPE-C24P防水前插后贴H10.65
UNIT: mm [inch]	CHECKED BY: 李毅	DATE : 2015.08.18	PART NO. SEE TABLE
SCALE: 1:1 SIZE: A4	APPROVED BY: 张少辉	DATE : 2015.08.18	MOLD NO.
			DRAW NO: ZDHS2400FS100
			SHEET NO. 1 OF 1

RECOMMEND P.C.B LAYOUT (COMPONENT SIDE)

TOLERANCE FOR PCB LAYOUT IS ± 0.05

KEEP OUT AREA

REV.	DESCRIPTION	ECN NO.	DWN.	CHK.	APVD.	DATE
A	NEW DAWING	ECN NO.	Rain	Chain	DC	2016 04 05

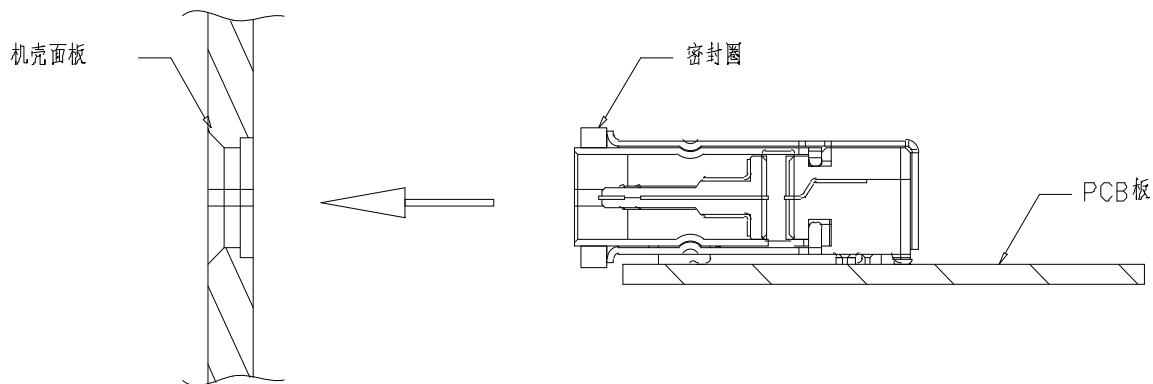

组装方式, 左右方向装配

机壳面板对密封圈与缩量0.30Min
(建议压缩量为密封圈直径大小40-50%)

机壳面板对密封圈与缩量0.30Min
(建议压缩量为密封圈直径大小40-50%)

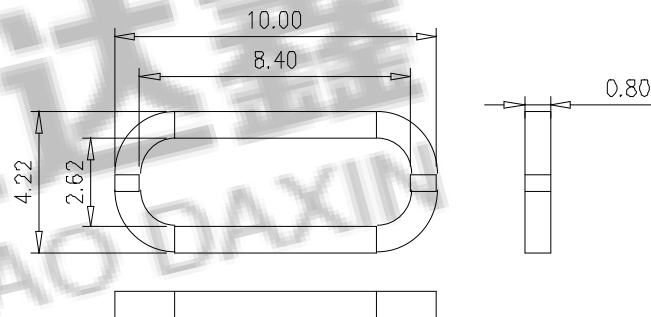

建议防水圈规格(材质硅橡胶)

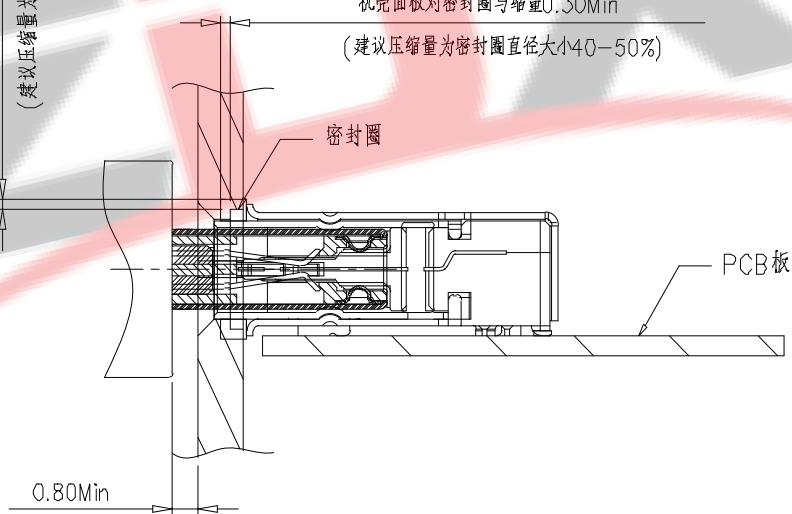

组装面板后公母头对插示意图

REV.	DESCRIPTION	ECN NO.	DWN.	CHK.	APVD	DATE
A	NEW DRAWING	ECN NO.	Leiny	Chain	DC	2016 04.05

ZDX 深圳市兆达鑫科技有限公司
Shenzhen Zhao Xin Technology Co., Ltd.

TOLERANCE: X.X ±0.30 X.XX ±0.20 X.XXX ±0.10 X.XX ±0.10 X.X ±0.05 X.X ±0.05 X.X ±0.05	DRAWN BY:	DATE:	PART NAME:	
	刘志强	2015.08.18	TYPE-C24P防水前插后贴H10.65	
	CHECKED BY:	DATE:	PART NO.	SEE TABLE
UNIT: mm [inch] SCALE: 1:1 SIZE: A4	李毅	2015.08.18	MOLD NO.	
	APPROVED BY:	DATE:	DRAW NO:	ZDHS2400FS100
张少辉	2015.08.18	SHEET NO.	1 OF 1	

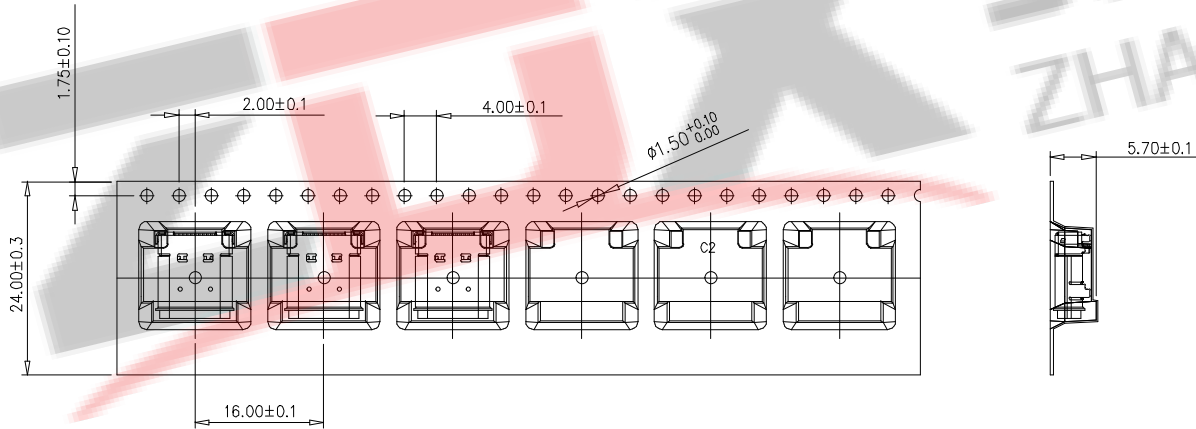
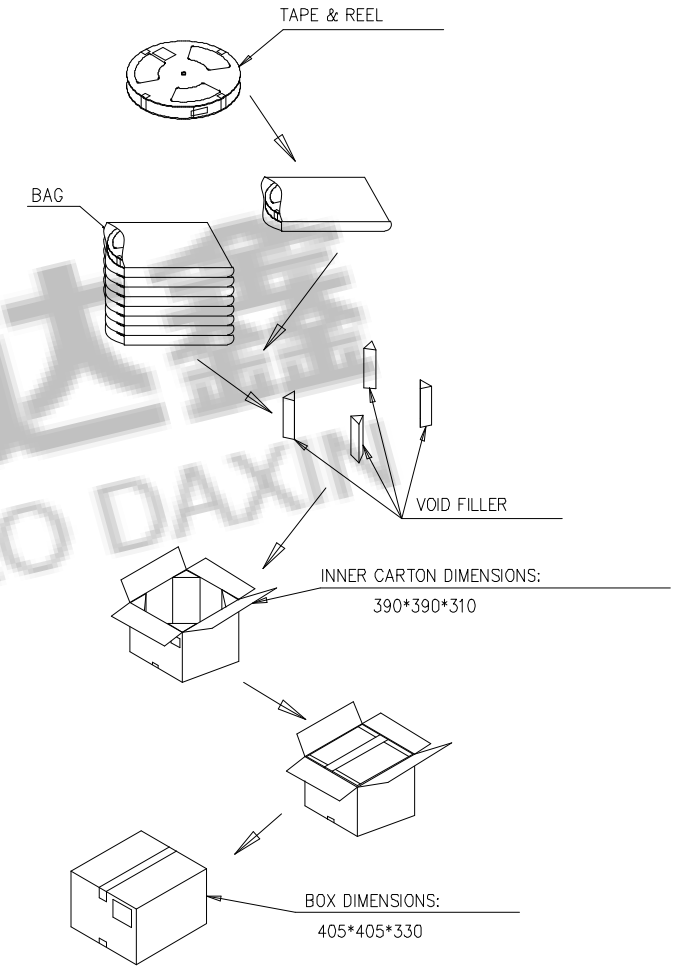
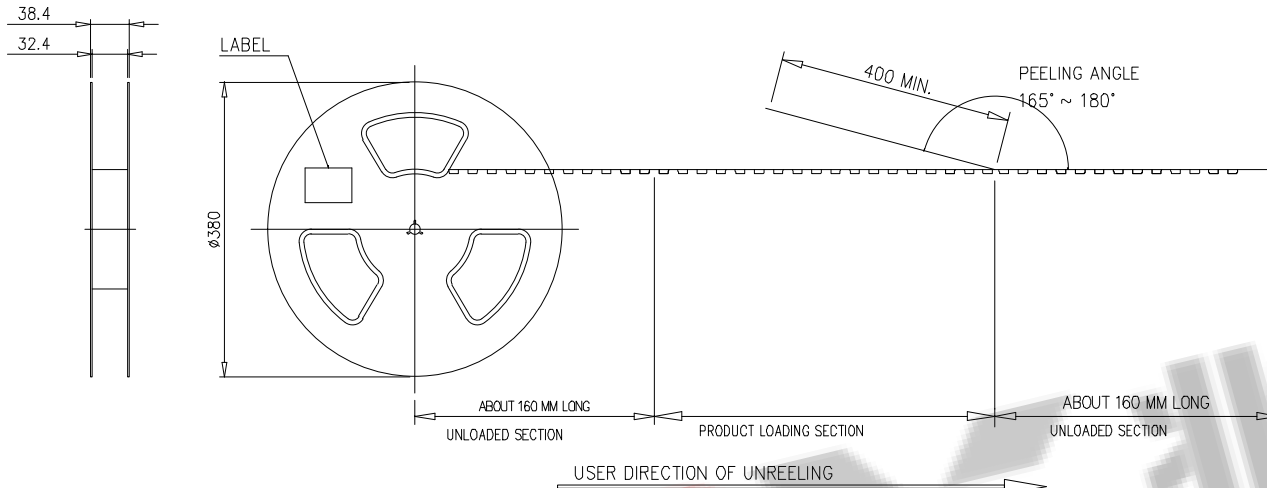

NOTE:

- 1.MATERIAL:
BOX: FIBREBOARD, CORRUGATED, DOUBLE WALL.
TAPE: POLYSTYRENES, HEAT-RESISTANT TEMPERATURE: 120°C, BLACK COLOR.
REEL: POLYSTYRENES, HEAT-RESISTANT TEMPERATURE: 70°C, BLUE COLOR.
BAG: POLYETHYLENE, HEAT-RESISTANT TEMPERATURE: 100°C.

2.PEELING STRENGTH: 0.1 ~ 1.3 N (10 ~ 130 GRAMS)

3.PEELING SPEED: 300 mm/min.

4.EACH BAG SHALL BE INCLUDED DESICCANT.

1250	10	12500 PCS	-- KG	-- KG
PCS/ REEL	REELS/ CARTON	QUANTITY	GROSS WEIGHT	NET WEIGHT

ZDX 深圳市兆达鑫科技有限公司
Shenzhen Zhao Xin Technology Co., Ltd.

TOLERANCE: X.XX ±0.30 X.XXX ±0.20 X.XXX ±0.10 X.X ±0.10 X.X ±0.05	DRAWN BY : 刘志强	DATE : 2015.08.18	PART NAME: TYPE-C24P防水前插后贴H10.65	
UNIT: mm [inch] SCALE: 1:1 SIZE: A4	CHECKED BY: 李毅	DATE : 2015.08.18	PART NO.	SEE TABLE
	APPROVED BY: 张少辉	DATE : 2015.08.18	MOLD NO.	
			DRAW NO:	ZDHS2400FS100
			SHEET NO.	1 OF 1