

- NOTES:
1. MATERIAL: SEE "TABLE 1";
  2. FINISH: SEE "TABLE 1";
  - 3 ELECTRICAL :
    - 3-1.CONTACT CURRENT RATING :
      - 5A(VBUS PIN 1.5A/PIN),
      - 5A(5VND PIN 1.25A/PIN MAX),0.25A/PIN(OTHER PIN).
    - 3-2.INSULATION RESISTANCE :
      - 100 MEGAΩHMS MIN. AT 25OVDC.
    - 3-3.DIELECTRIC WITHSTANDING VOLTAGE
      - 100VAC MIN.
    - 3-4.LOW LEVEL CONTACT RESISTANCE :
      - INITIAL 40mΩ MAX.
      - AFTER 50mΩ MAX.
  - 4.MECHANICAL CHARACTERISTICS .
    - 4-1. MATING FORCE: 5-20N ;
    - 4-2. UNMATING FORCE: 8-20N(INITIAL),6-20N(AFTER 10000 CYCLES);
    - 4-3.DURABILITY : 10,000 MATING CYCLES.
    - 4-4.OPERATING TEMPERATURE : -40°C TO +80°C



Pin	Signal Name	Mating Sequence	Pin	Signal Name	Mating Sequence
A1	GND	First	B12	GND	First
A2	SSTXp1	Second	B11	SSRXp1	Second
A3	SSTXn1	Second	B10	SSRXn1	Second
A4	Vbus	First	B9	Vbus	First
A5	CC1	Second	B8	SBU2	Second
A6	Dp1	Second	B7	Dn2	Second
A7	Dn1	Second	B6	Dp2	Second
A8	SBU1	Second	B5	CC2	Second
A9	Vbus	First	B4	Vbus	First
A10	SSRXn2	Second	B3	SSTXn2	Second
A11	SSRXp2	Second	B2	SSTXp2	Second
A12	GND	First	B1	GND	First
SHELL	GND		SHELL	GND	

RECOMMENDED P.C.B LAYOUT(Both sides are sample)  
Tolerance:±0.05, Thickness=0.60mm



**深圳市兆达鑫科技有限公司**  
Shenzhen Zhao Xin Technology Co., Ltd.

TOLERANCE: X.XX ±0.30 X.XXX ±0.20 X.XXX ±0.10 X.X ±0.10 X.X ±0.05		DRAWN BY : <b>刘志强</b>	DATE : 2015.08.18	PART NAME: <b>TYPE-C 24P防水沉板直口L9.65</b>	
UNIT: mm [inch] SCALE:1:1 SIZE: A4		CHECKED BY: <b>李毅</b>	DATE : 2015.08.18	PART NO.	SEE TABLE
		APPROVED BY: <b>张少辉</b>	DATE : 2015.08.18	DRAW NO.: ZDHS2400FS096	
				SHEET NO.: 1 OF 1	

建议密封方式

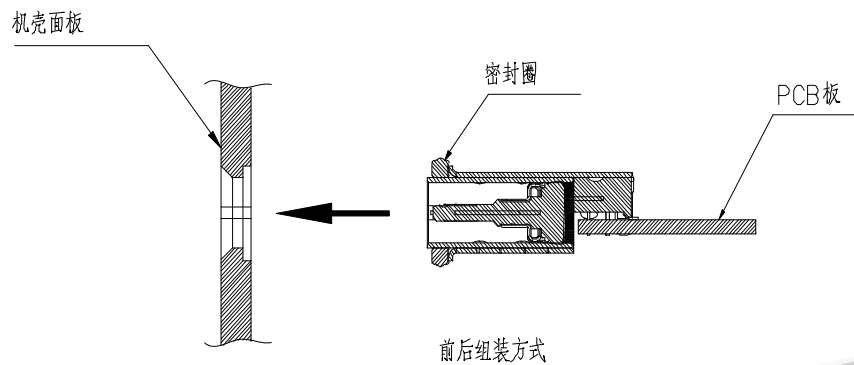

前后组装方式

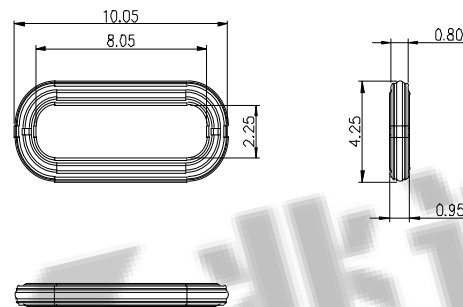

建议防水圈规格 (材质硅橡胶)

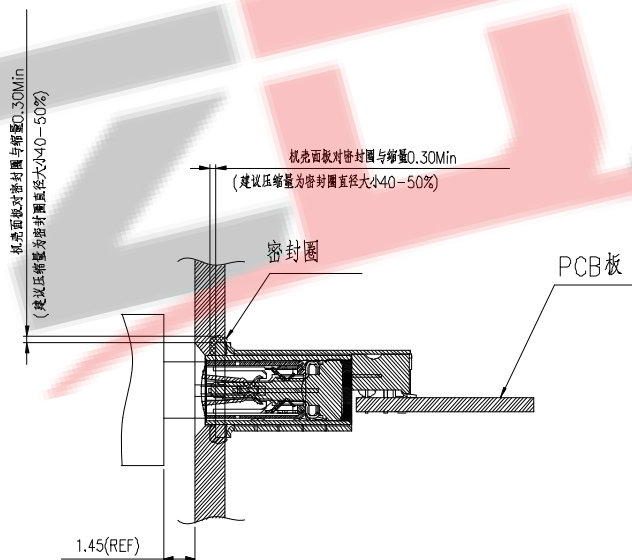

组装面板后公母头对插示意图

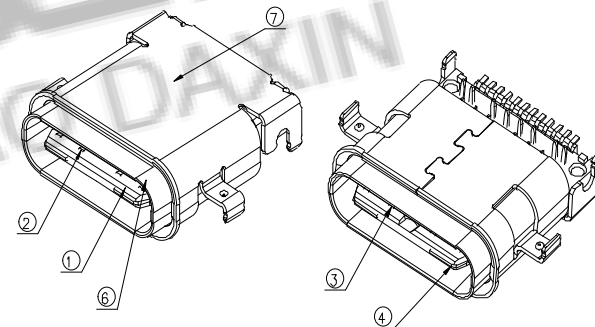

TABLE 1:

NO.	PART NAME	QTY	MATERIAL	DESCRIPTION	REMARK
⑧	GLUE WATER	1	EPOXY	BLACK	
⑦	Shell-2	1	Stainless steel	N PLATING	T=D 20mm
⑥	Shell-1	1	Stainless steel	N PLATING	T=D 20mm
⑤	GND PLATE	1	Stainless steel	N PLATING	T=0.10mm
④	MID PLATE	1	Stainless steel		T=D 15mm
③	Terminal-B	12	铜镍硅合金	Au 15 $\mu$ PLATING	T=0.12mm
②	Terminal-A	12		Au15 $\mu$ PLATING	T=D 12mm
①	Housing	1	HIGH TEMP	Black	

**ZDX** 深圳市兆达鑫科技有限公司  
Shenzhen Zhao Xin Technology Co., Ltd.

TOLERANCE: X.X ±0.30 X.XX ±0.20 X.XXX ±0.10 X.XX ±0.10 X.X ±0.10 X.X ±0.10 X.X ±0.10	DRAWN BY :	DATE :	PART NAME:	
	刘志强	2015.08.18	TYPE-C 24P防水沉板直口L9.65	
UNIT: mm [inch] SCALE: 1:1 SIZE: A4	CHECKED BY :	DATE :	PART NO.	SEE TABLE
	李文毅	2015.08.18	MOLD NO.	
APPROVED BY : 张少辉	DATE :	DRAW NO.:	ZDHS2400FS096	
	2015.08.18	SHEET NO.	1 OF 1	