

Circuit Diagram

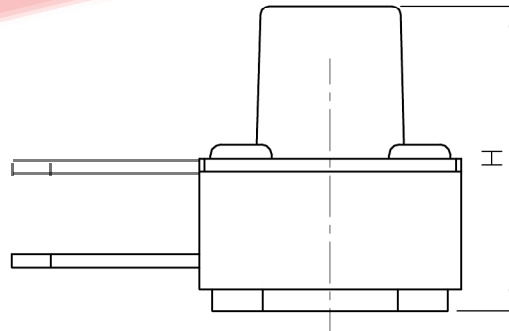
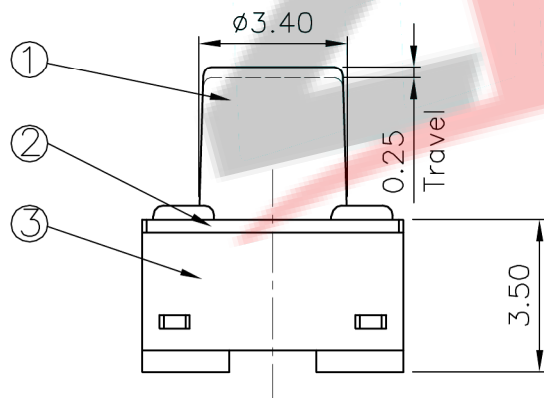

NO.1			
PART NO	H	PART NO	H
A	4.3	O	11
B	4.5	P	11.5
C	5	Q	12
D	5.5	R	12.5
E	6	S	13
F	6.5	T	13.5
G	7	U	14
H	7.5	V	15
I	8	W	16
J	8.5	X	17
K	9	Y	18
L	9.5	Z	19
M	10	1	15.5
N	10.5		

NO.2	
PART NO	vigor
1	90±30
2	130±30
3	180±30
4	250±30
5	350±50

NO.3	
PART NO	MATERIAL/QTY
S	SUS/1PC
C	C5210/1PC
D	SUS/2PCS
F	C5210/2PCS

NO.4-NO.5	
PART NO	NOTE
01~99	SERIAL NUMBER

⑤	Terminal	—	2	Brass(0.30t)	Plating silver	—
④	Contact	—	1	F.Ag/SUS	Plating silver	—
③	Base	—	1	Nylon	Black	—
②	Cover	—	1	SPCC	Plating Nickel	—
①	Keystoke	—	1	Nylon	Black	—
ITEM	PART NAME	TER'NO.	QTY.	MATERIAL	FINISHING	REMARK

APPROVALS			DATE		ZDX 深圳市兆达鑫科技有限公司 Shenzhen Zhao Xin Technology Co., Ltd.	
DRAWN	刘志强		2015.08.18		TITLE:	TACT SWITCHS
CHECKED	李文毅		2015.08.18		PART NO.	6*6边三脚
APPROVALS	张少辉		2015.08.18			
TOLERANCES ARE		30~以上	±0.30	ANGLE	UNIT: mm	SCALE: 1:1
		10~30	±0.20			
		5~10	±0.15			
		~ 5	±0.10			
			±2'		DRAWING NO.	
						SHEET 1 OF 1

ECN NO.	REV.	DATE.	DESCRIPTION.	CHANGE.	CHECK.	APPRO.
	A		NEW			