

A1	GND	B12	GND
A2	SSTXP1	B11	SSRXP1
A3	SSTXN1	B10	SSRXN1
A4	VBUS	B9	VBUS
A5	CC1	B8	SBU2
A6	DP1	B7	DN2
A7	DN1	B6	DP2
A8	SBU1	B5	CC2
A9	VBUS	B4	VBUS
A10	SSRXN2	B3	SSTXN2
A11	SSRXP2	B2	SSTXP2
A12	GND	B1	GND
PIN	SIGNAL NAMF	PIN	SIGNAL NAM

NOTE:

1.MATERIAL SPECIFICATION:

- 1.HOUSING:HIGH TEMPERATURE RESISTANT PLASTIC,UL94 V-0.
- 2.CONTACTS:COPPER ALLOY
- 3.MID PLATE: STAINLESS STEEL
- 4.FRONT SHELL: STAINLESS STEEL

2.PLATING SPECIFICATION:

2-1.CONTACTS:

Ni 50u" MIN. UNDER PLATED OVER ALL.

Au PLATED ON THE FUNCTIONAL AREA OF CONTACT.

(GOLD PLATING THICKNESS FOLLOW THE P/N)

PLATING SPECIFICATIONS OF THE SOLDER AREA FOLLOW THE P/N

2-2.FRONT SHELL:

SEE TABLE1.

2-3.SHIELD PLATE&EMI PLATE:

CLEAR ONLY

3.MECHANICAL PERFORMANCE,

- 3-1.INSERTION FORCE: 0.5~2.0kgf.
- 3-2.REMOVAL FORCE: 0.8kgf~2.0kgf.
- 3-3.DURABILITY: 5000 CYCLES.

4.ELECTRICAL PERFORMANCE,

- 4-1. CURRENT RATING: 3.0A
VOLTAGE RATING: 5.0V
- 4-2. LLCR:
VBUS & GND PINS AND OTHER PINS: 40mΩ/PIN MAX.
SHIELD: 50mΩ/MAX.
LLCR MAX. CHANGE OF ALL PINS: 10mΩ.
- 4-3.INSULATION RESISTANCE: 100MΩ MIN
- 4-4.DIELECTRIC WITHSTAND VOLTAGE,AC 100V FOR 1 MINUTE.

5. ENVIRONMENTAL PERFORMANCE:

OPERATING TEMPERATURE: -25°C~+85°C.

6.IR REFLOW:

THE PEAK TEMPERATURE ON THE BOARD SHALL BE MAINTAINED FOR 10 SECONDS AT 260°C.

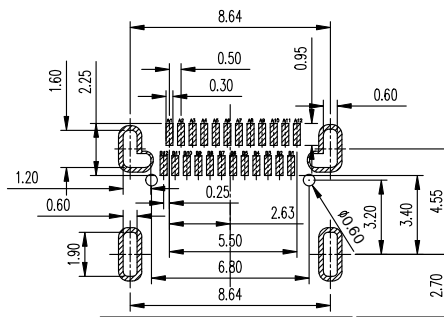
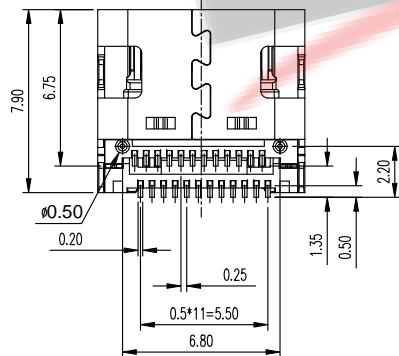
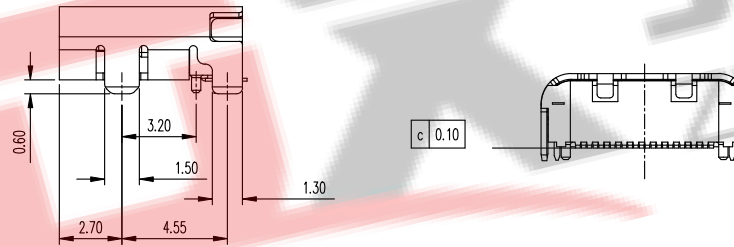
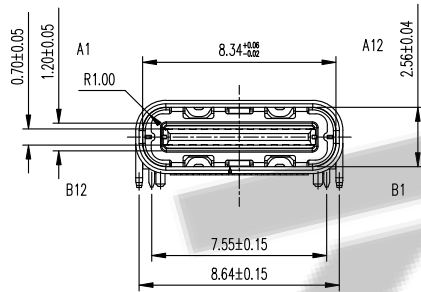
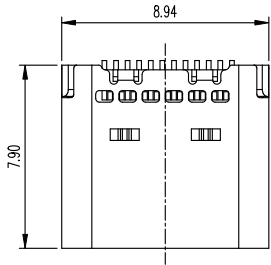

RECOMMENDED P.C.B LAYOUT
TOP VIEW(TOLERANCE±0.05)

深圳市兆达鑫科技有限公司 Shenzhen Zhao Xin Technology Co., Ltd.			
TOLERANCE: X.X ±0.30 X.XX ±0.20 X.XXX ±0.10 X.XX ±0.10 X.X ±0.05 X.X ±0.05	DRAWN BY : 刘志强	DATE : 2015.08.18	PART NAME: TYPE-C24P四脚插板双贴片H7.9
UNIT: mm [inch] SCALE:1:1 SIZE: A4	CHECKED BY: 李文毅	DATE : 2015.08.18	PART NO. SEE TABLE MOLD NO.
	APPROVED BY: 张少辉	DATE : 2015.08.18	DRAW NO: ZDJNKJ00002416 SHEET NO. 1 OF 1

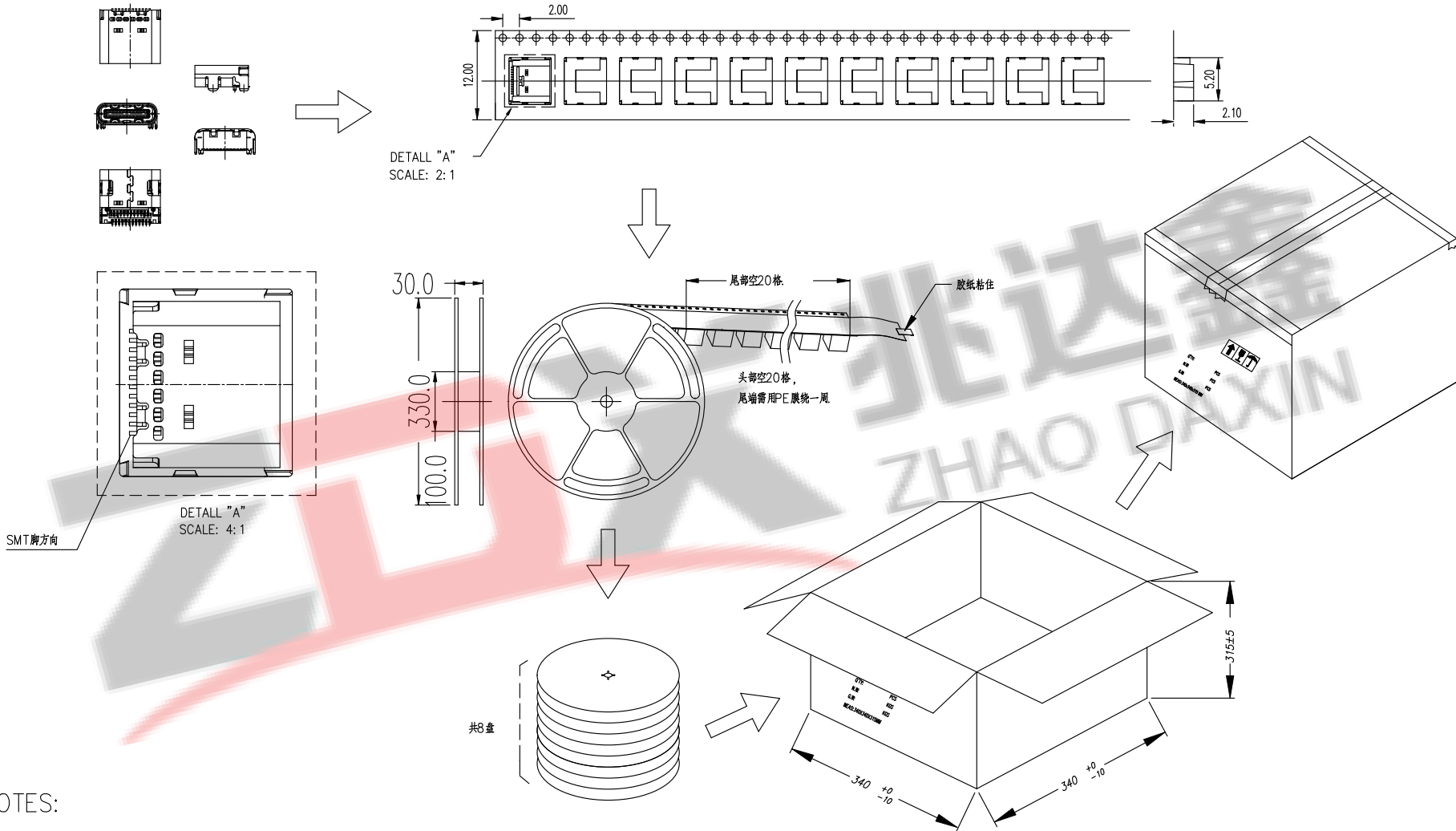

NOTES:

1. 每卷装产品1000PCS。
2. 每箱装产品8X1000=8000PCS。
3. 卷盘规格为: 13寸/盘
4. 纸箱规格为: 340MM*340MM*315MM

深圳市兆达鑫科技有限公司 Shenzhen Zhao Xin Technology Co., Ltd.			
TOLERANCE: X.XX ±0.30 X.XXX ±0.20 X.XXX ±0.10 X.X ±0.10 X.X ±0.05 X.X ±0.05	DRAWN BY : 刘志强	DATE : 2015.08.18	PART NAME: TYPE-C24P四脚插板双贴片H7.9
UNIT: mm [inch] SCALE: 1:1 SIZE: A4	CHECKED BY: 李文毅	DATE : 2015.08.18	PART NO. SEE TABLE MOLD NO.
	APPROVED BY: 张少辉	DATE : 2015.08.18	DRAW NO.: ZDJNKJ00002416 SHEET NO.: 1 OF 1