

特性:

一、电气性能: EICTRICAL

1. 额定电流: 5.0A
2. 接触阻抗: 40 MILLIOHMS MAX
3. 耐电压: 100V AC / 1 mA MAX
4. 绝缘阻抗: 150V DC/100 MEGA OHMS MIN

二、机械性能:

1. 插入力: 5~20N
2. 拔出力: 8~20N
3. 使用寿命: 10000次, 拔出力 5N MIN

三、材料: MATERIAL

四、电镀: FINISH

1. 端子: 接触点镀金1U"MIN
PIN脚焊接区域镀锡80U"MIN
2. 外壳: 镀镍80U"MIN (盐雾48H)

5. 电镀品需做粘锡测试: 粘锡面积达到95%以上。
6. SMT回流焊(峰值260°C±5°C)不能起泡、熔胶、变色不良(变形在公差范围以内)
7. 工作温度: -55°C~+85°C
8. 盐雾测试: 通过48H在浓度为5±1%盐水的盐雾测试无生锈现象

A1	A2	A3	A4	A5	A6	A7	A8	A9	A10	A11	A12
GND			VBUS	CC1	D+	D-	SBU1	VBUS			GND
GND			VBUS	SBU2	D-	D+	CC1	VBUS			GND
B12	B11	B10	B9	B8	B7	B6	B5	B4	B3	B2	B1

BOM				
序号	名称	料号	用量	品名规格
1	外壳		1	Typec立插 外壳 SUS304 T=0.30mm
2	Molding 3		1	Typec立插 DIP 16PIN Molding C7025 LCP黑色 半成器
2.1	Molding 1		1	Typec立插 DIP 16PIN Molding A C7025 LCP黑色
2.2	Molding 2		1	Typec立插 DIP 16PIN Molding B C7025 LCP黑色
2.3	卡勾		1	Typec立插 16PIN 卡勾 SUS301 T=0.15mm

ZDX 深圳市兆达鑫科技有限公司
Shenzhen Zhao Xin Technology Co., Ltd.

TOLERANCE: X.XX ±0.30 X.XXX ±0.20 X.XXX ±0.10 X.X ±0.10 X.X ±0.05 X.X ±0.02	DRAWN BY:	DATE:	PART NAME:	
	刘志强	2015.08.18	TYPE-C16PIN立式贴板H8.8	
	CHECKED BY:	DATE:	PART NO.	SEE TABLE
	李毅	2015.08.18	MOLD NO.	
	APPROVED BY:	DATE:	DRAW NO.:	ZDJNKJ00001610
	张少辉	2015.08.18	SHEET NO.:	1 OF 1

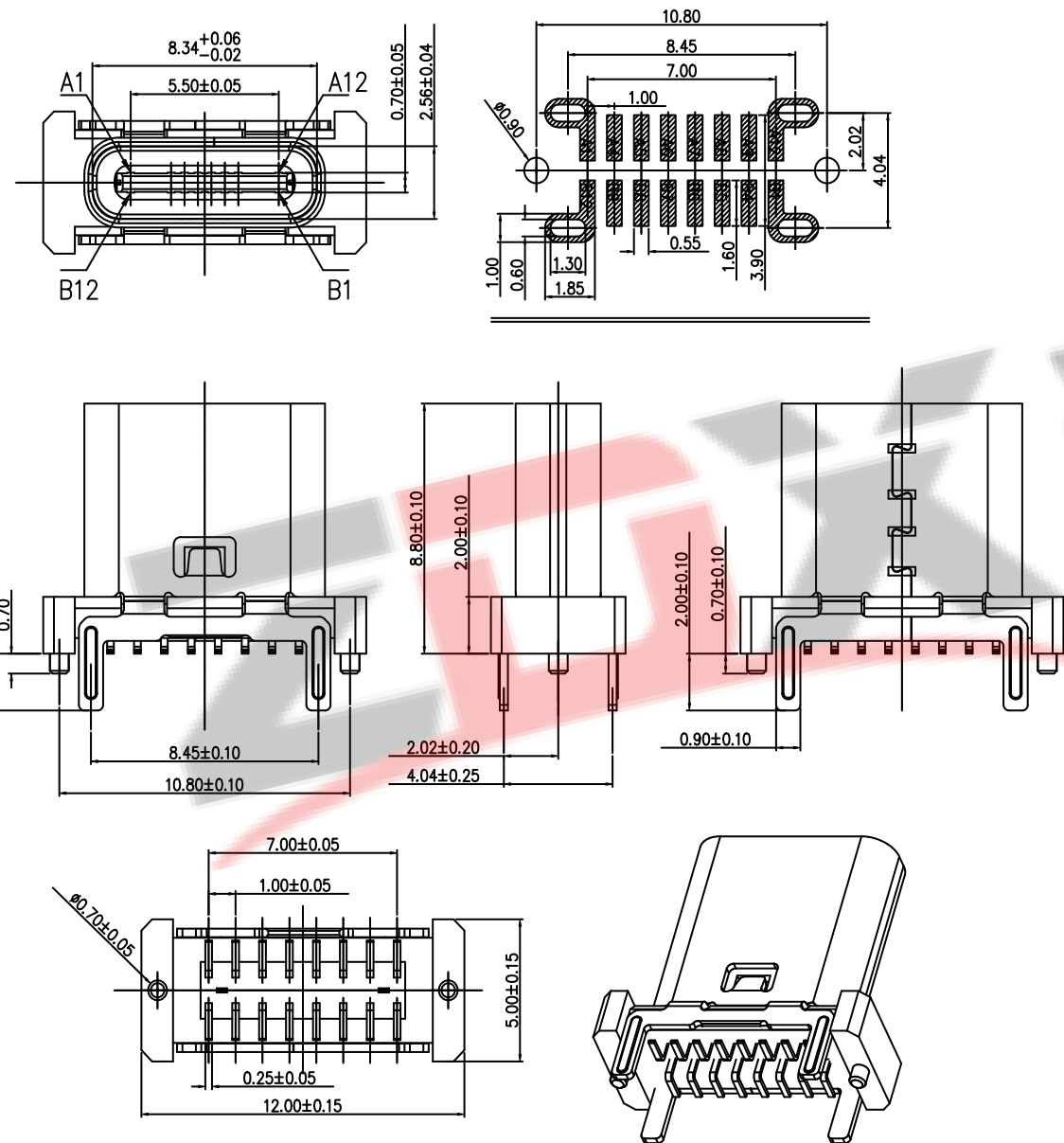

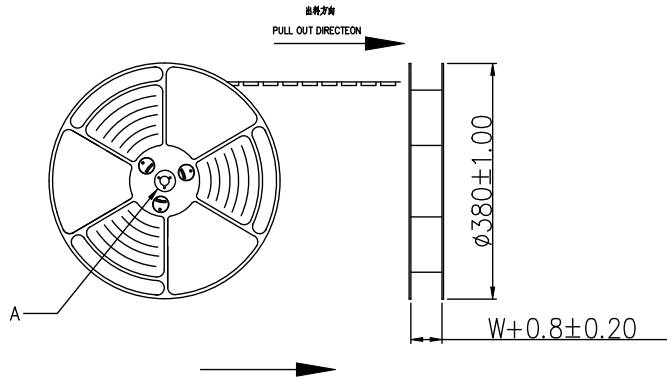

at small positioning hole of the carrier tape side.
 粘 (朝 零件的小定位孔一)
 Location of label sticking (label)

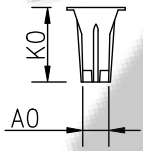
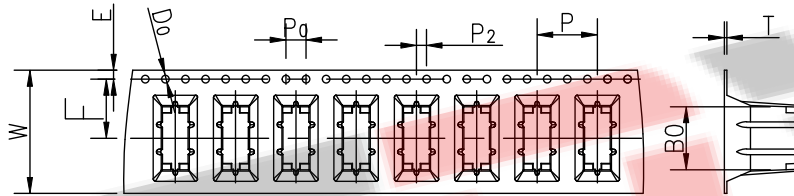
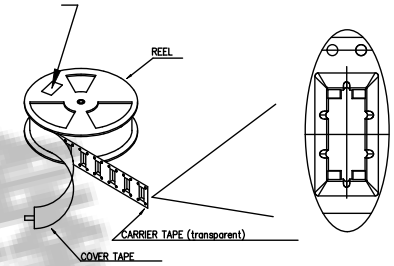
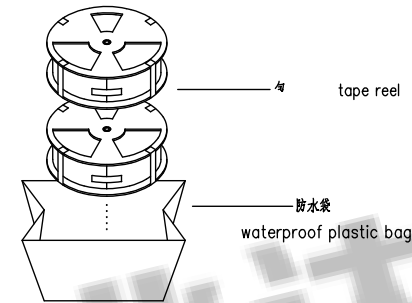

NOTES
 1. 子带长度
 LEAD TAPE LENGTH
 出料方向
 PULL OUT DIRECTION

2. 上 拉力 : 0.1~1.3N(10.2gf~130gf)
 PEELING OFF FORCE OF TOP TAPE: 0.1~1.3N(10.2gf~130gf)
 出料过程中
 THIS REQUIREMENT SHOULD BE APPLIED AT SHIPMENT:
 禁止 撕带
 PEELING OFF SHOULD NOT BE ALLOWED DURING TRANSPORTATION

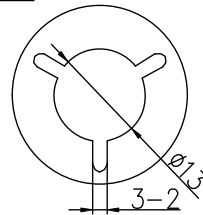
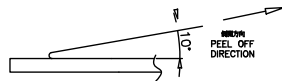

DETAIL: A
 10:1

箱: 390mmX390mmX300mm

NOTE:

1. 每包量及每箱量如左下表格。
 Packing q'ty of each reel & carton as below table shown.
2. 产品的卷放入箱并以封口。
 Put reels in the carton and use adhesive tape to seal up.

W	24.00±0.3
A0	5.24±0.1
B0	12.30±0.1
K0	10.55±0.1
P	12.00±0.1
F	11.50±0.1
E	1.75±0.1
D0	1.50±0.1
P0	4.00±0.1
P2	2.00±0.1
T	0.50±0.05

卷带	规格: $\phi 380\text{mm}$	包装数量: 600PCS
纸箱	规格: 390mmX390mmX300mm	包装数量: 8盘(4800PCS)

ZDX 深圳市兆达鑫科技有限公司
 Shenzhen Zhao Xin Technology Co., Ltd.

TOLERANCE: X:XX ±0.30 X:XX ±0.20 X:XXX ±0.10 X:· ±10° X:· ±5°	DRAWN BY : 刘志强	DATE : 2015.08.18	PART NAME: TYPE-C16PIN立式贴板H8.8
UNIT: mm [inch] SCALE: 1:1 SIZE: A4	CHECKED BY: 李毅	DATE : 2015.08.18	PART NO. SEE TABLE MOLD NO.
	APPROVED BY: 张少辉	DATE : 2015.08.18	DRAW NO: ZDJNKJ00001610 SHEET NO. 1 OF 1